

Flow sensor IUF

with 2 ultrasonic measuring paths for combination with calculators for measurement of thermal energy (heating or cooling)

Nominal flow q_p 15 to q_p 600 m³/h

Nominal diameter DN 50 to DN 300

The flow sensors IUF serve to record the heat carrier volume (water) in closed circulation systems of heating or cooling plants. The scope of application reaches from measuring points in buildings to district heating or cooling networks .

The recorded volume can be output either in the form of conventional volume pulses or via an optional data interface (type VMCP / Volume Meter Cycle Protocol).

Particularly noteworthy is the compatibility with the short case lengths of Woltman WP flow sensors, so that these mechanical devices can now be easily replaced by ultrasonic technology without the need for expensive reconstruction of the respective measuring point.

To complete a measuring point for thermal energy, a calculator and a pair of temperature sensors are required.



Performance characteristics at a glance

- High-quality and durable housing, up to nominal size DN 100 made of stainless steel
- 2 ultrasonic measuring paths for precise flow measurement
- MID type examination certificat DE-19-MI004-PTB031 in the metrological class 2
- Supplementary German type examination certificat DE-20-M-PTB-0012 for cooling applications
- No straight inlet or outlet sections required
- Permanent temperature load up to 105 °C or 130 °C, depending on the version
- Any installation position (even "head down")
- Optional data interface for transmission of volume, flow rate, flow direction and device status
- Continuous nominal diameters from DN 50 to 300, including DN 125
- Ideal for calibration replacement of Woltman flow sensors of type WP and WS due to compatible overall lengths
- Can be combined with the ZENNER multidata WR3 or other standard energy calculators
- Optional possibility of integrating a temperature sensor or pressure sensor with threaded connection ½"

Flow sensor IUF

Technical data										
Nominal diameter DN	mm	50	65	80	100	125	150	200	250	300
Nominal flow q_p	m ³ /h	15	25	40	60	100	150	250	400	600
Maximum flow q_s	m ³ /h	30	50	80	120	200	300	500	800	1.200
Minimum flow q_i	m ³ /h	0.15	0.25	0.4	0.6	1	1.5	2.5	4	6
Typical starting value	m ³ /h	0.01	0.02	0.03	0.05	0.08	0.1	0.2	0.3	0.4
Pulse value*	l / pulse	25	25	25	25	250	250	250	250	250
Duration of the pulse*	ms	100								
Metrological class	Class 2 acc. EN 1434-1									
Pressure loss at q_p	mbar	46	34	33	37	51	53	63	56	54
Flow rate at 100 mbar pressure loss	m ³ /h	22	43	70	99	140	206	315	535	816
Media temperature range	°C	Standard version: $1 \leq \Theta q \leq 105$ Special version (on request): $1 \leq \Theta q \leq 130$ (150 for ≤ 2.000 hours)								
Minimum pressure to avoid cavitation	bar	3 at the meter outlet at nominal flow and 150 °C								
Heat carrier	Water									
Overall length (selective)	mm	200 270	200 300	225 300	250 360	250 350	300 350 500	350 500	400 600	450 500
Nominal pressure/peak pressure (selective for DN 100 and 150)	PN/PS	25	16 (L 200 mm) 25 (L 300 mm)	25	16 25	16	16 25	16	16	16
Installation position	In any position									
IP protection class	IP 68, optional IP 65									
Energy supply	Lithium battery 3.6 V DC, Battery lifetime: up to 12 years									
External power supply	Optional, 5 ... 24 V DC									
Volume pulser	Open drain / class OC acc. EN 1434-2 Maximum input voltage: 12 V DC Maximum input current: 10 mA									
Data interfaces	Type VMCP (Volume Meter Cycle Protocol)									
Length pulse cable	m	5 (extendable by 7 meters with extension set, article 152146) total max. 20								
Ambient conditions	Ambient temperature: 5 ... 55 °C Storage temperature range: -20 ... +55 °C Mechanical class: M2 Electromagnetic class: E2 Maximum height of installation point: 2000 meter above mean sea level									
Installation point for temperature sensors or pressure sensor (optional)	Internal thread 1/2", factory sealed									

*Standard values, other values on request

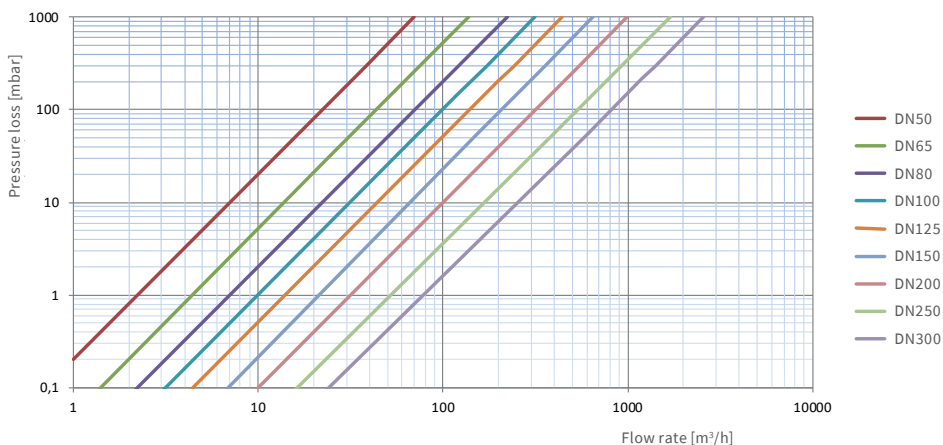

Pressure loss curve

Flow sensor IUF

Weight and dimensions											
Nominal diameter	DN	mm	50	65	80	100	125	150	200	250	300
Overall length	L	mm	200	200	225	250	250	300	350	400	450
			270	300	300	360	350	350	500	450	500
Weight without packaging approx.		kg	7	8	10	13	22	27	35	49	67
			9	11	15	20	28	36	46	53	89
Weight incl. packaging approx.		kg	9	10	12	15	23	29	40	55	75
			11	13	17	22	31	40	52	70	95
Height	H	mm	221	232	253	273	360	390	450	510	565
Height	H1	mm	65	70	90	100	125	130	170	203	230
Width	B	mm	172	190	205	230 (235)	250	285 (300)	340	405	460
Flange diameter	D		165	185	200	220 (235)	250	285 (300)	340	405	460
Hole diameter	K		125	145	160	180 (190)	210	240 (250)	295	355	410
Bolt diameter	D1	mm	18	18	18	18 (22)	18	22 (26)	22	26	26
Number of bolts		pcs.	4	4 (8)	8	8	8	8	12	12	12

The values in brackets are valid for operating pressure MAP 25

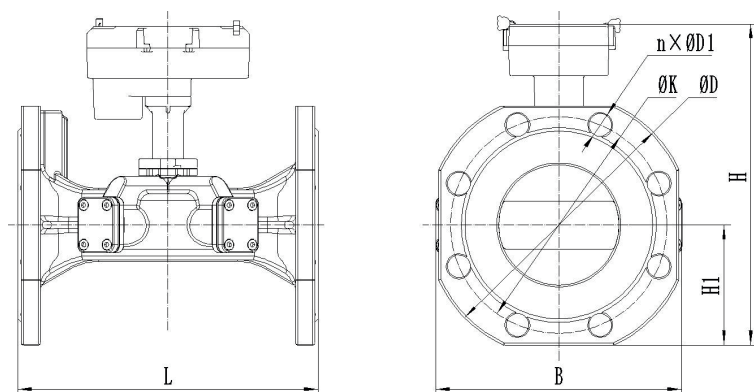

Dimensions DN 50 - DN 100

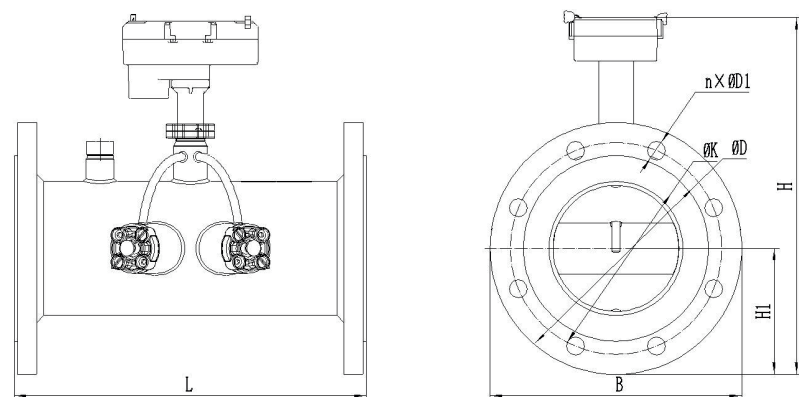

Dimensions DN 125 - DN 300

ZENNER International GmbH & Co. KG

Heinrich-Barth-Straße 29
66115 Saarbrücken
Germany

Phone +49 681 99 676-30
Fax +49 681 99 676-3100
E-Mail info@zenner.com
Internet www.zenner.com